



DRUM SIEVE MACHINE



MMCTECH
Investment And Consultancy INC

DRUM SIEVE MACHINE

Efficient pre-cleaning machine for high input capacities.

Pre-cleaning process decreases the maintenance requirements of the machines but also gives high quality of cleaning products. Drum sieve efficient at removing over and undersize impurities such as pieces of wood, stone etc.. from product. This makes it necessary to have drum sieve machine in input section of seeds storage and transfer facilities or in processing lines . The different drum screens sizes available from 10 to 60mm.

All movable components are enclosed and this provides effective protection to operating personnel. Confidential pre-cleaning process with the drum sieving machine avoids damages to downstream processing machinery. This improves the operational dependability of the entire production plant.

The use of high quality components makes the machine highly resistant to wearing down. So that decreases maintenance requirements and increases the machine's service life.

The overhanging screening drum gives quick and easy replacement of screen. Enclosed design of the machine and the aspiration vent ensures that area around the machine also remains clean at all times.



TECHNICAL SPECS

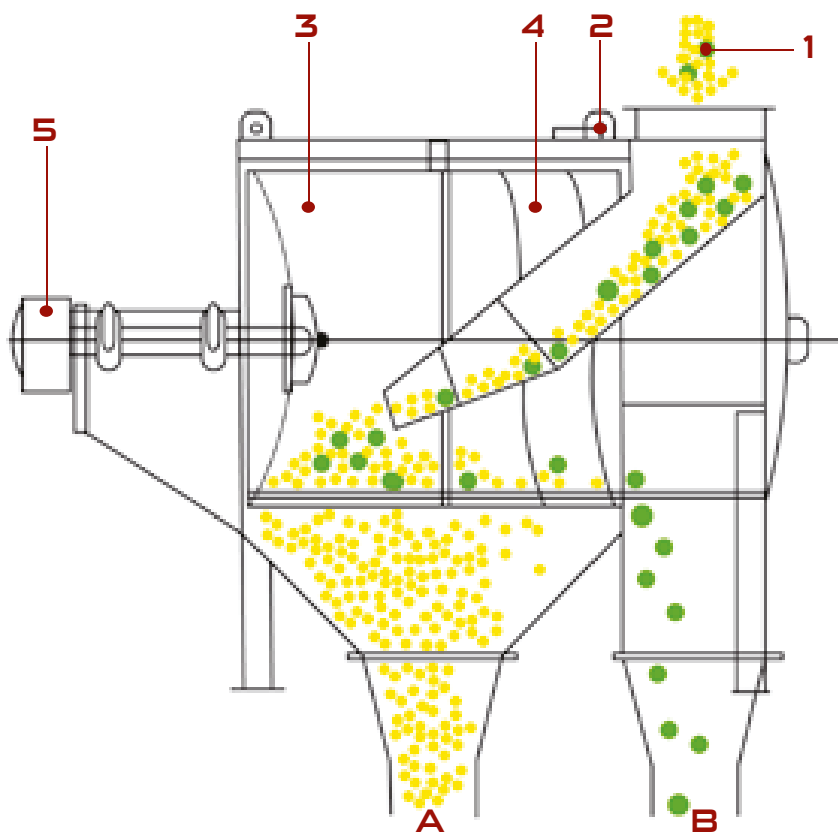

Working principle of Drum Sieve Machine

- 1) Product inlet
- 2) Exhaust air
- 3) Inlet cylinder
- 4) Discharge cylinder with guide screw
- 5) Motor

- A) Main product
- B) Oversize particles

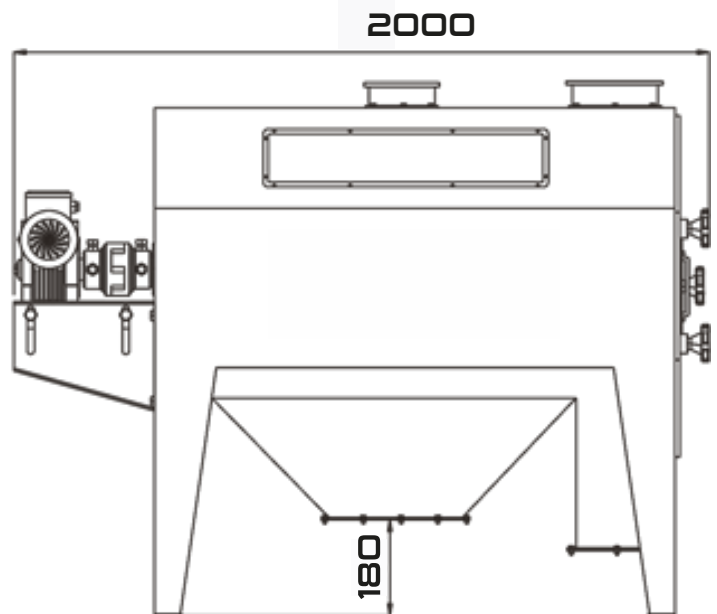
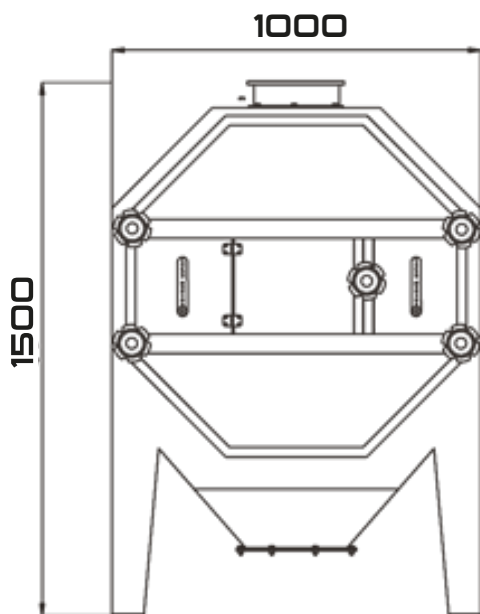

| Model | In Put Cleaning Capacity | | Overall Diemensions | | | | Air Volume | Weight |
|-----------|--------------------------|-----------------------|---------------------|--------|--------|--------|------------|---------|
| | Plant Pre-Cleaning | Storage Pre -Cleaning | A (mm) | B (mm) | C (mm) | D (mm) | | |
| AKDS-1000 | 5-15 T/h | upto 200 t/h | 1000 | 2000 | 1500 | 180 | 3,00 | 360(kg) |

MMCTECH DRUM SIEVE MACHINE

