



MULTI SEPARATOR

Working Principle

Multi Separator

Mode of operation: The first cleaning stage involves the separation of all oversize and undersize particles. The scalping sieve removes all impurities that are larger than the grain kernel, for example straw, strings and large stones. The sand sieve eliminates all impurities smaller than the grain kernel, for example sand, broken kernels and foreign seeds. The next important step involves sorting the product into a heavy and a mixed fraction, with particles of the same size being separated according to their specific gravity. Separation is based on the differences in the flow velocity of the various Product fractions: Heavy particles contact the oscillating sieve bottom and flow to the subsequent de-stoning stage, whereas the clean grain floats on a cushion of air to the product outlet.

The separation of low-density particles such as dust, hulls, chaff, shriveled kernels and foreign seeds is accomplished by air classification.

The Multi Separator combines the following four processing steps in a single machine:

- The Separator separates according to size (coarse impurities)
- The Concentrator sorts according to specific gravity (fine impurities)
- The De-stoner removes stones
- The Aspirator eliminates low-density particles and dust

Benefits

- Optimal preparation for grinding
- Clean products
- High product safety
- Low operational cost

Design

- Compact, space-saving design
- Sturdy design
- One machine housing for four operations
- One common vibrator drive
- One machine frame
- Easy adjustment of the sieve box inclination
- One coarse screen with final separation stage and two sand sieve decks
- Adjustable division into a heavy and a mixed fraction
- Variable final separation of stones
- Double-adjustable wall in the aspiration channel
- Fine regulation of the air velocity for separation of the light fraction
- Central aspiration connection
- With or without air-recycling system
- Aspiration channel with interior lighting

Features

- Easy operation and maintenance due to:
 - Easy fine-tuning
 - Monitoring on a single floor
 - No lubrication points
 - No power transmissions
- High sanitation due to simple, functional design
- High efficiency due to reduction of:
 - Space requirement and building costs
 - Aspiration lines and filter surface area
 - Power requirement and energy costs
 - Installation time and costs
 - Gravity spouting
 - Electric connections and cables
 - Maintenance work and personnel
- Efficient cleaning and successful grain processing

Flowchart

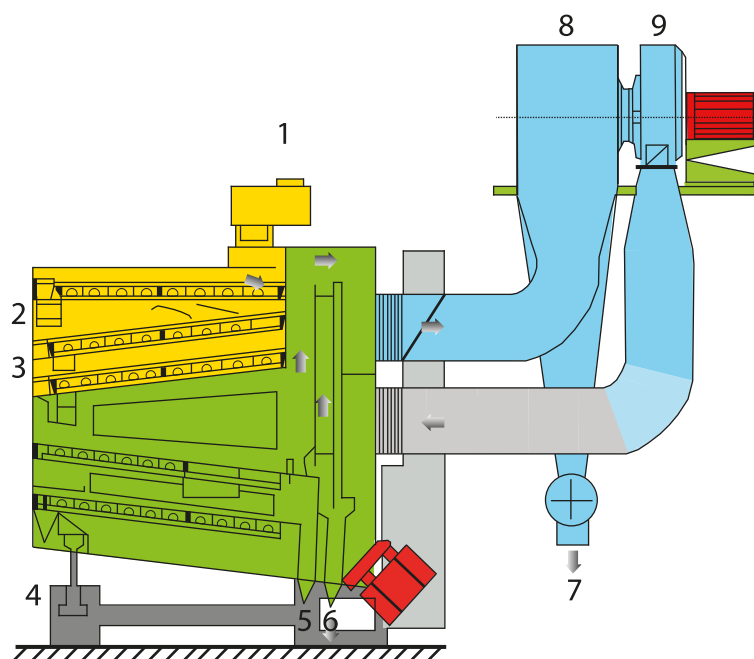

- ① Product Inlet
- ② Coarse Impurities
- ③ Sand
- ④ Stones
- ⑤ Heavy Fraction
- ⑥ Mixed Fraction
- ⑦ Light Fraction
- ⑧ Air-recycling Separator
- ⑨ Aspiration Connection

MULTI SEPARATOR

Optimal Efficiency in Seed and Grain Sorting with Mmctech

www.mmctech.us
info@mmctech.us



Technical Drawing

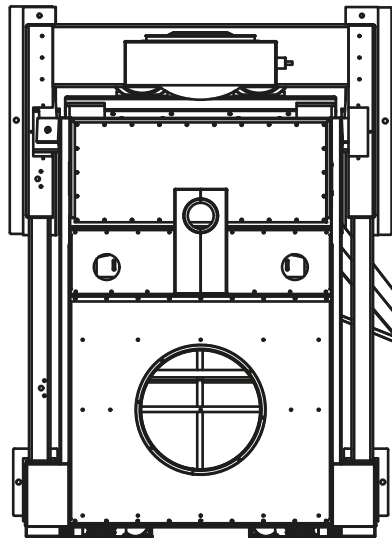
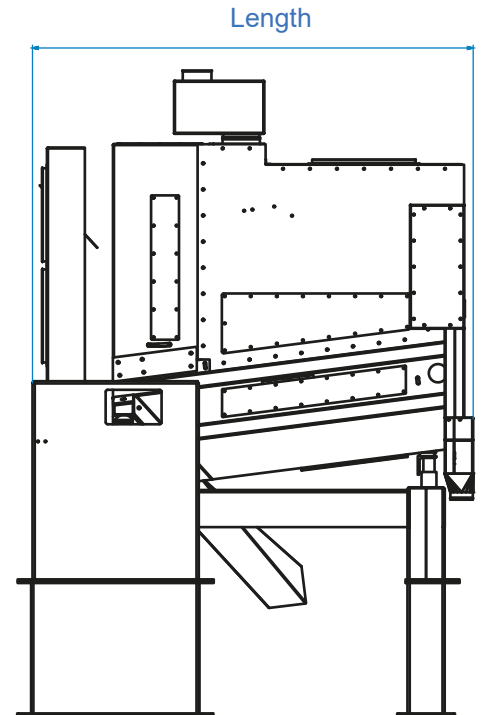
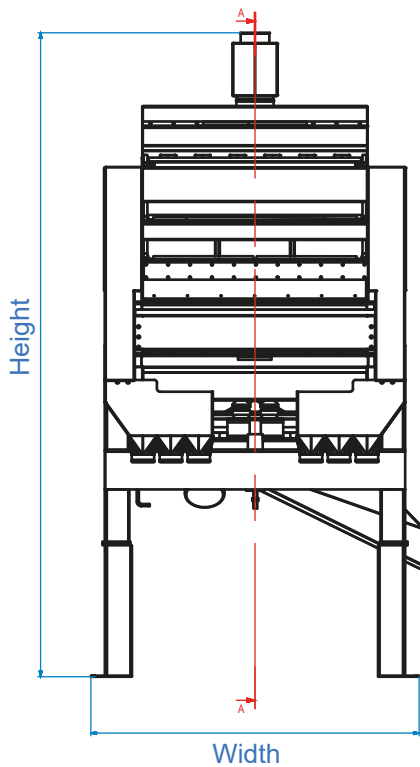

Technical Chart

Dimensions (mm)				
Type	Height	Width	Length	Weight
Multi SG-DS-GS	3458 cm	1763 cm	2366 cm	1750 kg

Technical Data							
Type	Capacity in t/h wheat (approx. values)	Aspiration with/without air-recycling system m ³ /min	Power requirement vibrator kW	Approx. weights in kg			Volume Seapacking m ³
				Net	Gross	By sea	
Multi SG-DS-GS	3-12	90	2x0,75	1650	1800	2000	9.0

MULTI SEPARATOR



Grading Greatness: Mmctech Inc's Multi Seed Separator

www.mmctech.us - info@mmctech.us

