



# MMCTECH

www.mmctech.us

info@mmctech.us

SEED PROCESSING MACHINE & EQUIPMENTS - AUTOMATION SOLUTIONS

## RADYAL TARAR

Ürün Kodu ARA-100  
ARA-150

## AIR-RECYCLING ASPIRATOR

Product Code ARA-100  
ARA-150



### Makinanın Görevi

Radyal Tarar, bakliyat ve tahıl fabrikalarında ve tohum temizleme tesislerinde tahıl içerisindeki düşük yoğunluğa sahip olan maddelerin ayrıştırılmasında kullanılmaktadır. Makinenin genişliğinde homojen bir şekilde dağıtılan tahıl tanelerinden aerodinamik açıdan farklı olan her türlü parçacıkları yatay havalandırma kanalında çiftli ayarlanabilir duvarlar yardımıyla ayırır.

- Portatif bir makinedir.
- Merkezi aspiratör sisteminden bağımsız olarak çalışmasını sağlayacak aspiratör sistemine sahiptir.
- Radyal Tarar havanın % 100'nü çevirir, makinenin içerisindeki hava devamlı olarak tekrar tekrar kullanılır ve daha homojen ürün ve çalışma alanı oluşturulur.

### Work Principle

The air-recycling aspirator ARA is applied for the separation of low-density particles in an aspiration channel from granular products such as soft wheat, rye, barley, oats, beans, chickpeas, sunflower seeds, Sesame Seeds, corn (maize). High degree of separation thanks to excellent separating efficiency.

The air-recycling aspirator ARA is characterized by its excellent separating efficiency, which ensures a high degree of separation:

The uniform distribution of the air across the entire width of the aspiration channel and the dually adjustable wall in the vertical aspiration channel ensure stable and reliable separation.

The degree of separation can be selected with high precision, preventing unnecessary product loss.



ISO 9001 - 2008  
QUALITY ASSURANCE

Ürün Kodu/Product Code

**ARA-100**  
**ARA-150**

## Radyal Tarar Sistem Air-Recycling Aspirator

- 1- Eksantrik sürüclü ürün besleme  
1- Product feed with eccentric drive
- 2-Çift ayarlı vakum kanalı  
2- Aspiration channel with double adjustable wall
- 3- Hafif ürün ayırımı  
3- Integrated separator for low density product
- 4-Hava geri dönüşümü için radyal fan  
4- Radial fan for recycling air
- 5- Hava geri dönüşüm kanalı  
5- Air recycling channel
- 6- Hava hafif ürün boşatma helezonu  
6- Screw conveyor with discharge gate for low-density product
- 7- İyü ürün çıkış noktası  
7- Outlet with finger valves for discharge of heavy product

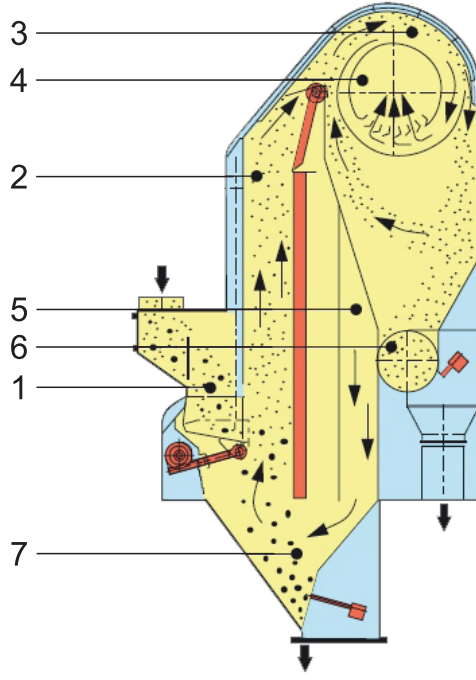

### Opsiyonel Yardımcı Ekipmanlar Optional Helper Equipments

Pre-Cleaner  
Vibratory Sieve Separator



Platform

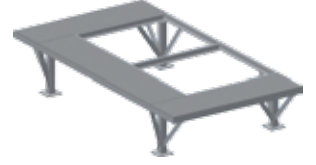

Ön Temizleme Eleği  
Vibro Çöp Sasörü

Platform

## Model ARA-150 Teknik Çizim Model ARA-150 Technical Drawing

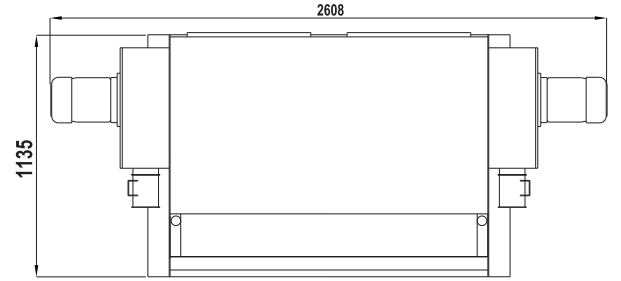
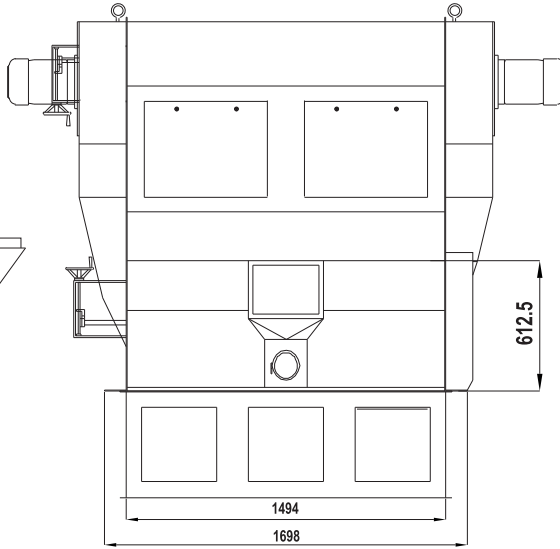
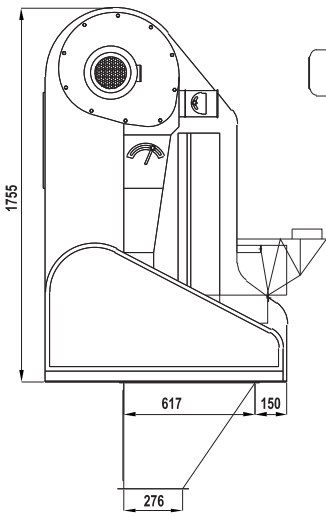

### Makinanın Detay Resimleri Detailed Photos



MMCTECH: Seed Machines & Equipment with Automation Solutions

www.mmctech.us

info@mmctech.us